

## Product Data Sheet

### 601 GP XX

Replace "XX" with 01 through 30 for number of poles

**Terminal Block– Open Back**  
20 Amps, 300 Volts (AC/DC)



**Insulator Strip Required for Voltage Rating**

**Copper Wire Only**

Wire Range with Wire Binding Screw: #12 - #22 AWG

7/16" Centers

Application torque: 9 in. lbs

#### **Electrical Ratings:**

- 20A with Listed ring lug or unprepared wire, (Based on NEC Table 310-16, 75°C columns)
- 300 Volts AC/DC (UL 1059 Class B, User Group – Commercial Appliances)
- Short Circuit Current Rating: 10,000A (Default)
- Approved for Factory and Field Wiring.

#### **Mechanical Ratings:**

- Insulator base temperature: -40°C to 150°C (302°F)\* UL RTI
  - Flammability rating of insulator base: UL 94V-1
- \* Use outside these ratings needs to be judged in the end-use application.

#### **Materials:**

- Connector (Eyelet): Brass, nickel plated.
- Insulator base: Phenolic
- Screw, #6-32 Binder head, Phil-Slot: Steel, nickel plated

#### **Agency Approvals:**

- UL Recognized, UL 1059 Terminal Block Standard, File No. XCFR2.E47811
- CSA Certified, CSA C22.2 No. 158, File No. LR19766
- CE compliant, IEC 60947-7-1
- RoHS Compliant

## Wire Range:

Wire Size	Torque		Copper Wire Stranding Classes - Number of Conductors		
	N-m	In. lbs	Solid	Class B	Class C
12	1.0	9	1	1	1
14	1.0	9	1	1	1
16	1.0	9	1	1	1
18	1.0	9	1	1	1
20	1.0	9	1	1	1
22	1.0	9		1	1

## Mounting:

Suggested product mounting hardware: #6 fastener, torque to 10-15 in. lbs.

## Accessories:

- JJ (GDI-30F) Material available. Glass-fiber filler, diallyl ortho-phthalate. UL-94 V0. Certifiable to Military Specifications MIL-M-14 and MIL-P-19833.

- Printing

- Marking strips - sub mounted, black only (FB) (For Printing Options, see section on website)



- Marking strips – top mounted, white only (SW)

- Insulator strips - sub mounted, black only (BB) (Printing Unavailable). Insulator Strip will be the same width as the molding.

- Cover – top mounted. Order CW (white) or CB (Black). Can be printed. See website.



- Phil-Slot Brass Screw (PSB)

**Accessory options may affect ratings – consult factory**

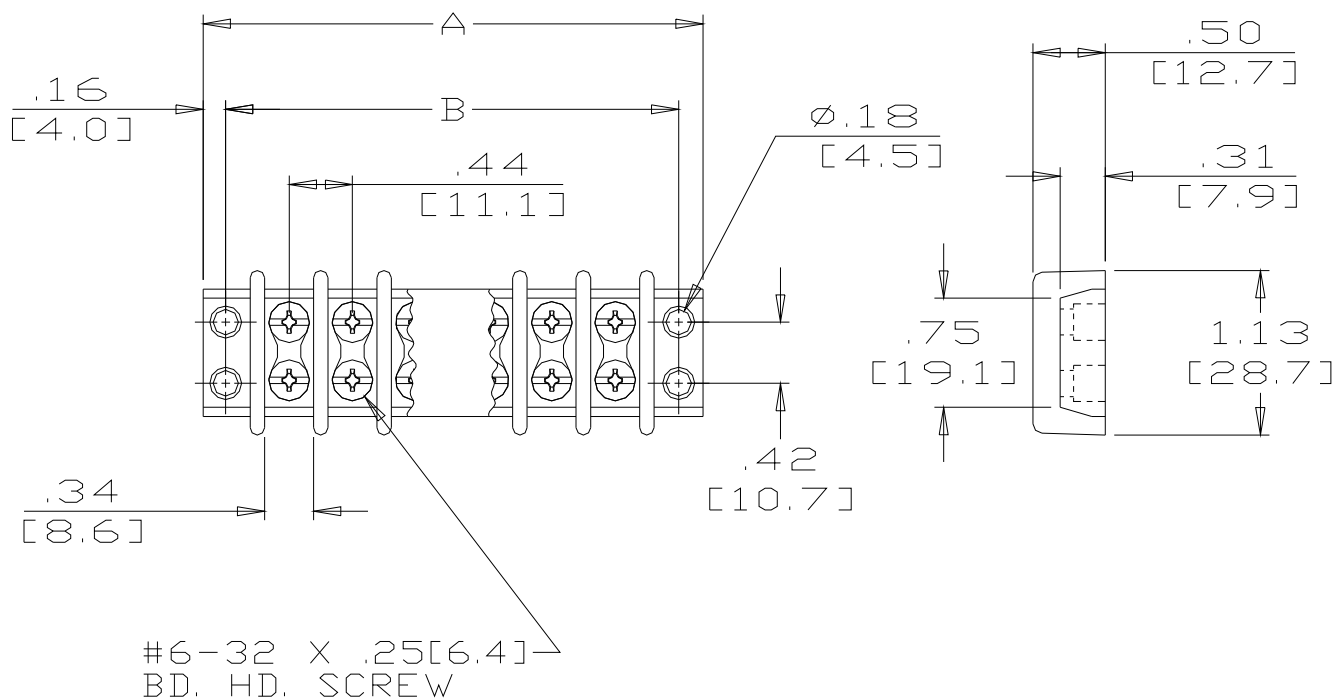

Catalog No	# of Poles	Dimensions			Catalog No	# of Poles	Dimensions	
		A	B				A	B
601 GP 01	1	1.19	0.88	X	601 GP 13	13	6.44	6.13
601 GP 02	2	1.62	1.31	X	601 GP 14	14	6.87	6.56
601 GP 03	3	2.06	1.75	X	601 GP 15	15	7.31	7.00
601 GP 04	4	2.50	2.19	X	601 GP 16	16	7.74	7.43
601 GP 05	5	2.94	2.63	X	601 GP 17	17	8.18	7.87
601 GP 06	6	3.37	3.06	X	601 GP 18	18	8.61	8.30
601 GP 07	7	3.81	3.50	X	601 GP 19	19	9.05	8.74
601 GP 08	8	4.25	3.94	X	601 GP 20	20	9.48	9.17
601 GP 09	9	4.68	4.37	X	601 GP 21	21	9.92	9.61
601 GP 10	10	5.12	4.81	X	601 GP 22	22	10.35	10.04
601 GP 11	11	5.56	5.25	X	601 GP 23	23	10.79	10.48
601 GP 12	12	5.99	5.68	X				

Top Mounted Hardware is .250" Wide

MM = Dim X 25.4